

Aire et Volume d'un Tronc de Cône (C)

Calculez l'aire et le volume de chaque tronc de cône.

$$\text{Aire} = \pi(r_1 + r_2)\sqrt{(r_1 - r_2)^2 + h^2} + \pi r_1^2 + \pi r_2^2 \quad \text{Volume} = \frac{\pi}{3}h(r_1^2 + r_2^2 + r_1 r_2)$$

1.

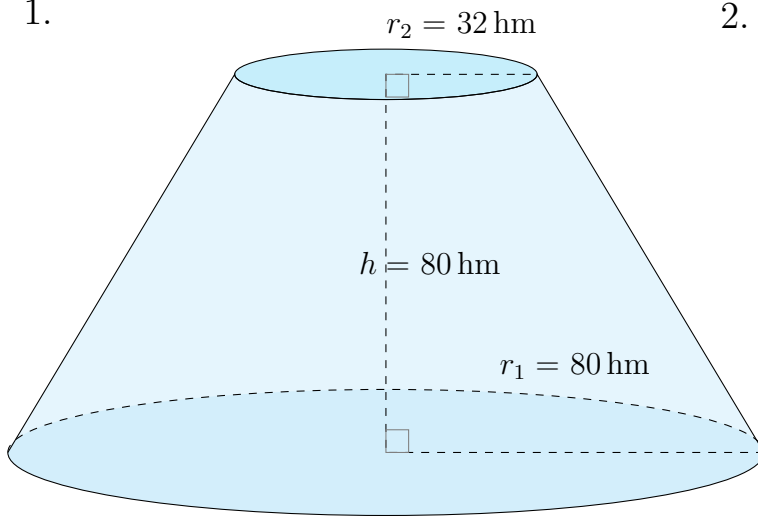

2.

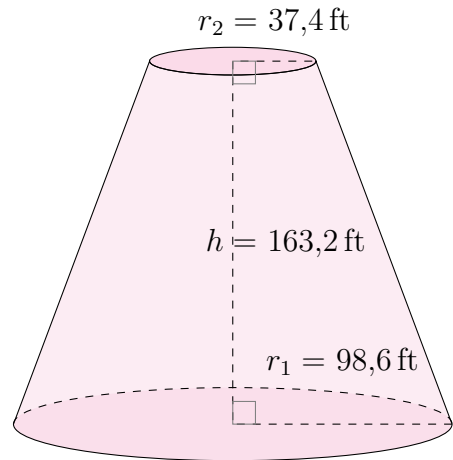

3.

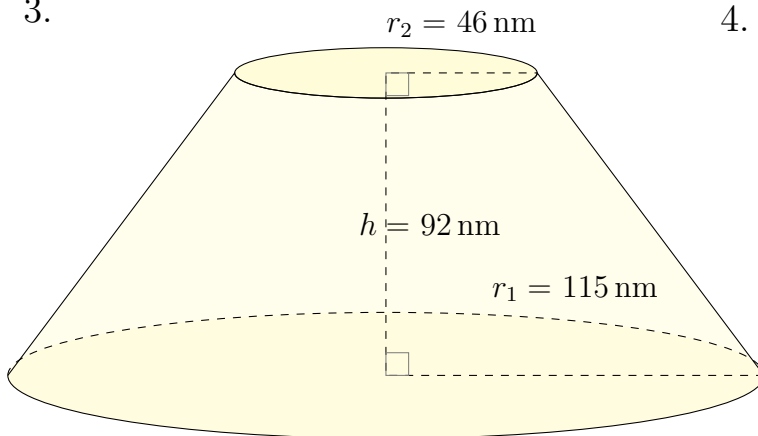

4.

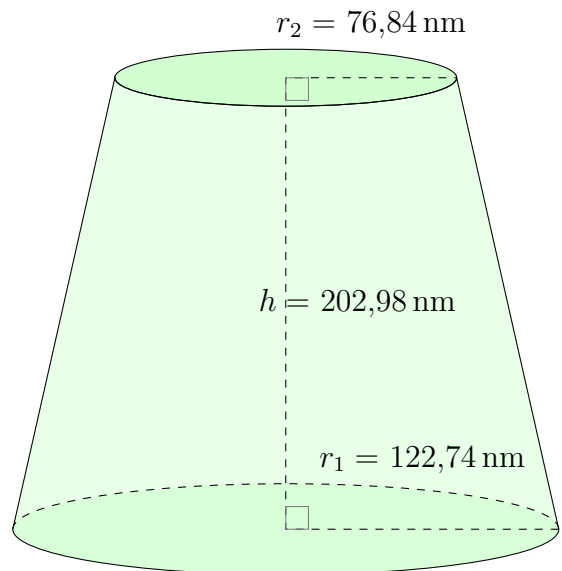

Aire et Volume d'un Tronc de Cône (C) Réponses

Calculez l'aire et le volume de chaque tronc de cône.

$$\text{Aire} = \pi(r_1 + r_2)\sqrt{(r_1 - r_2)^2 + h^2} + \pi r_1^2 + \pi r_2^2 \quad \text{Volume} = \frac{\pi}{3}h(r_1^2 + r_2^2 + r_1 r_2)$$

1.

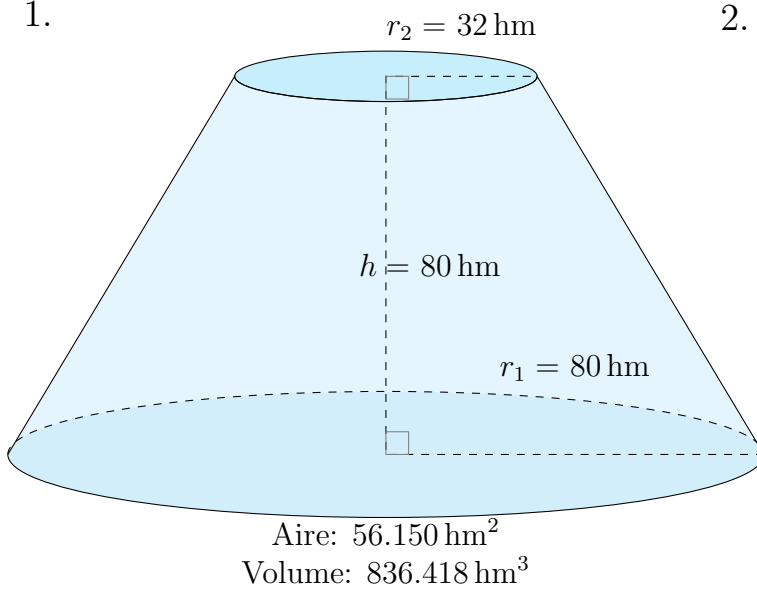

2.

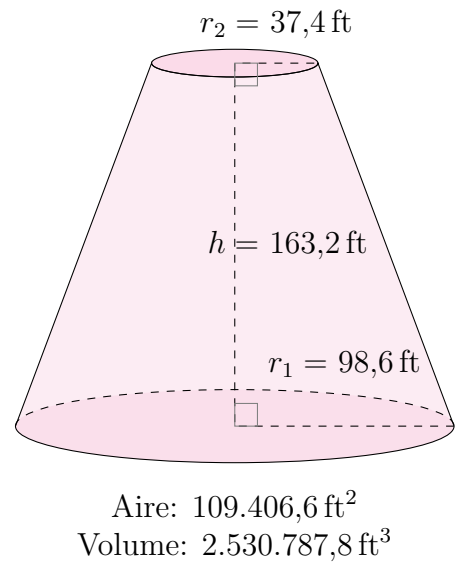

3.

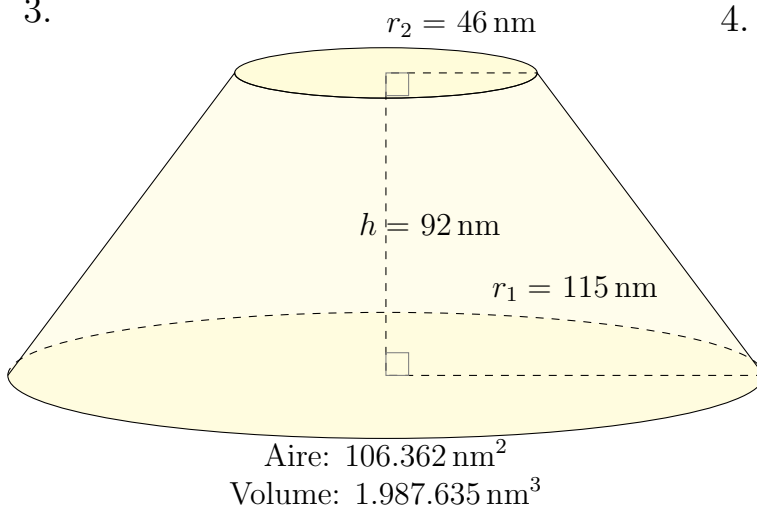

4.

