

Aire et Volume d'un Tronc de Cône (H)

Calculez l'aire et le volume de chaque tronc de cône.

$$\text{Aire} = \pi(r_1 + r_2)\sqrt{(r_1 - r_2)^2 + h^2} + \pi r_1^2 + \pi r_2^2 \quad \text{Volume} = \frac{\pi}{3}h(r_1^2 + r_2^2 + r_1 r_2)$$

1.

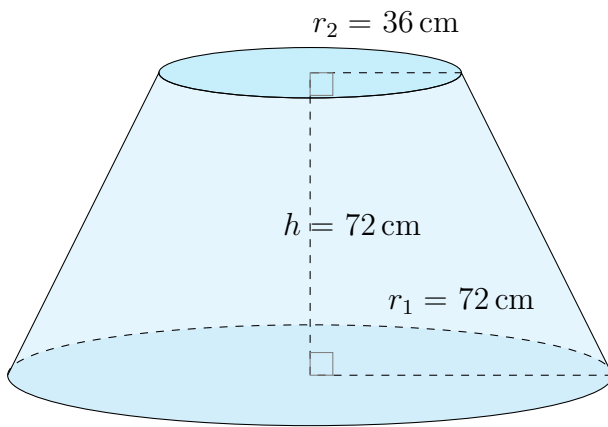

2.

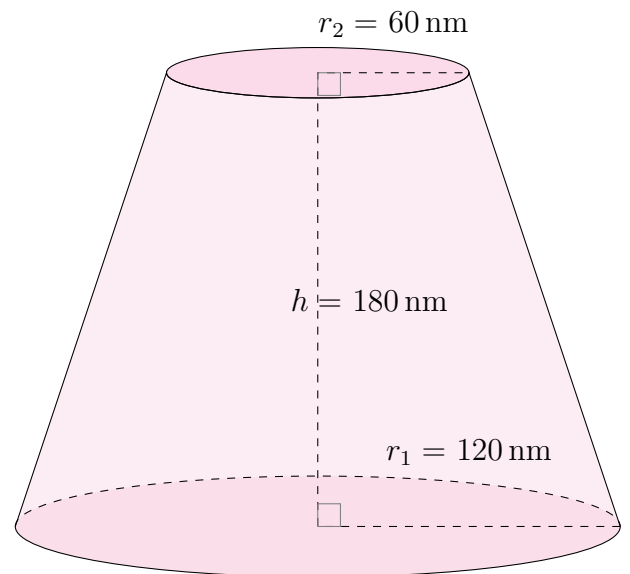

3.

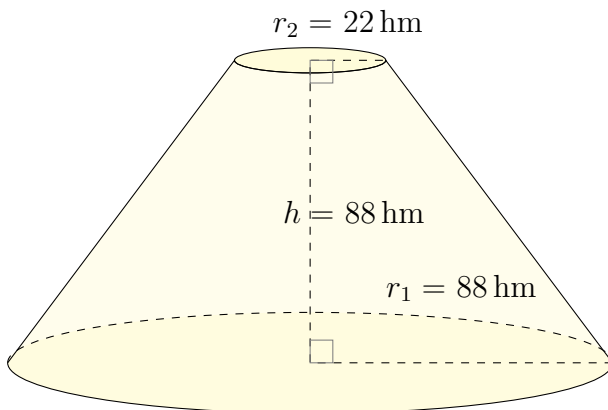

4.

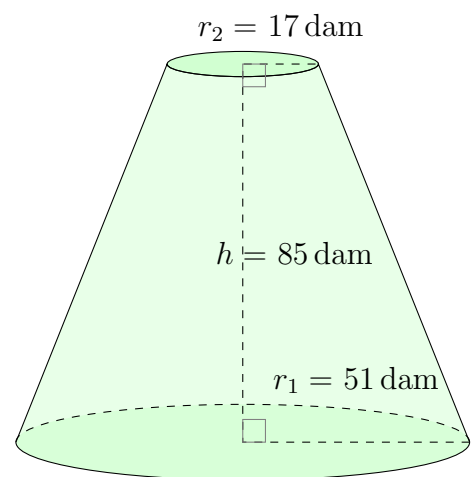

Aire et Volume d'un Tronc de Cône (H) Réponses

Calculez l'aire et le volume de chaque tronc de cône.

$$\text{Aire} = \pi(r_1 + r_2)\sqrt{(r_1 - r_2)^2 + h^2} + \pi r_1^2 + \pi r_2^2 \quad \text{Volume} = \frac{\pi}{3}h(r_1^2 + r_2^2 + r_1 r_2)$$

1.

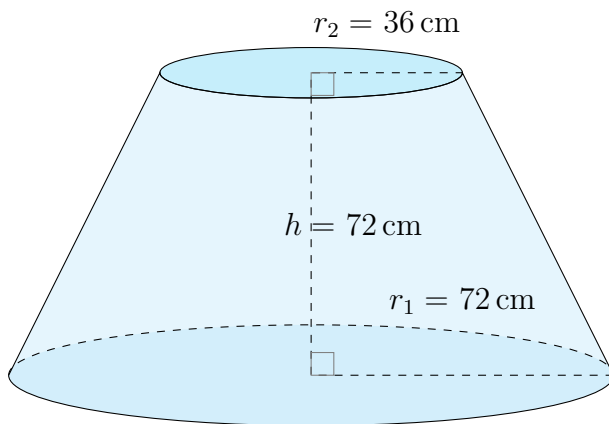

Aire: 47.670 cm^2
Volume: 684.013 cm^3

2.

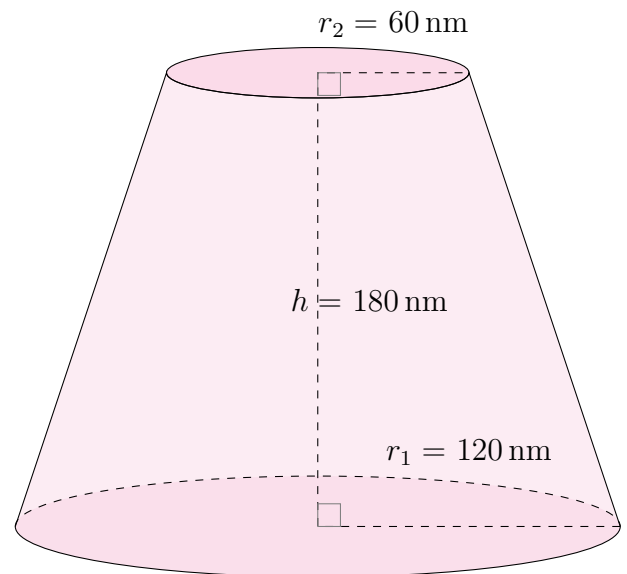

Aire: 163.842 nm^2
Volume: $4.750.088 \text{ nm}^3$

3.

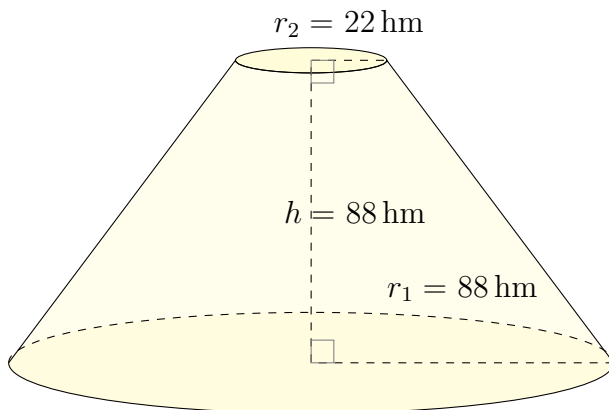

Aire: 63.862 hm^2
Volume: 936.647 hm^3

4.

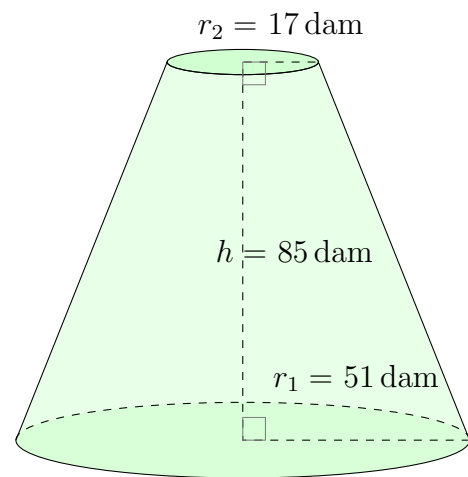

Aire: 28.636 dam^2
Volume: 334.417 dam^3